

ZETTLER DISPLAYS

SPECIFICATIONS FOR LIQUID CRYSTAL DISPLAY

CUSTOMER APPROVAL			
※ PART NO. : <u>ATM0154B1(ZETTLER DISPLAYS) SPEC VER1.9</u>			
APPROVAL		COMPANY CHOP	
CUSTOMER COMMENTS			

ZETTLER DISPLAYS ENGINEERING APPROVAL		
DESIGNED BY	CHECKED BY	APPROVED BY
GZC	XW	GuZH

REVISION RECORD

REVISION	REVISION DATE	PAGE	CONTENTS
VER1.0	2019-02-28	ALL	FIRST ISSUE
VER1.1	2019-06-28	6	ADD LIFETIME PARAMETER
VER1.2	2019-07-03	8	ADD BRIGHTNESS INFORMATION
VER1.3	2019-07-10	5,6	UPDATE PARAMETERS
VER1.4	2019-08-29	4	CHANGE SPEC FORMAT
VER1.5	2019-10-09	5	CHANGE LCD OUTLINE ,UPDATE FPC CONNECTOR
VER1.6	2020-03-02	10	UPDATE DESCRIPTION OF THE PIN "CS"
VER1.7	2020-06-18	5	UPDATE FPC STRUCTURE DIMENSIONS
VER1.8	2023-04-07	4	UPDATING MECHANICAL DRAWING
VER1.9	2024-12-24	ALL	UPDATE PRECAUTION AND SPECIFICATION FORMAT

※ **CONTENTS**

1. GENERAL SPECIFICATIONS
2. PIN ASSIGNMENT
3. OPERATING SPECIFICATIONS
4. OPTICAL SPECIFICATIONS
5. RELIABILITY TEST
6. PRECAUTION FOR USING LCM
7. MECHANICAL DRAWING
8. PACKAGE DRAWING
9. INSPECTION SPECIFICATION

1. GENERAL SPECIFICATIONS

Item	Specification	Remark
1. LCD size	1.54 inch(Diagonal)	
2. Driver element	a-Si TFT active matrix	
3. Resolution	240x(RGB)x240	
4. Display mode	Normally Black, IPS, Transmissive	
5. Dot Pitch (W*H)	0.0385mm(W) x 0.1155mm(H)	
6. Pixel pitch(W*H)	0.1155mm(W) x 0.1155mm(H)	
7. Active Area(W*H)	27.72mm(W) x 27.72mm(H)	
8. Module size (W*H)	31.52mm(W) x 33.72H) x1.95mm(D)	Note 1
9. Surface treatment	Anti-glare	
10. Color arrangement	RGB-stripe	
11. Color	262K	
12. Viewing angle (L/R/T/B)	80/80/80/80	
13. Interface	4-wire SPI interface	
14. LCD controller	ST7789V2	
15. LCM Brightness	500 cd/m2 Typ.	
16. Backlight driving condition	20mA @9.0V	
17. Touch panel(Coverlens)	N.A.	
18. Touch controller	N.A.	
19. Operation Temperature	-20~60 °C	
20. Weight	3.2g(Typ.)	
21. RoHS & REACH	RoHS & REACH compliant	

Note 1: Please refer to mechanical drawing.

2. PIN ASSIGNMENT

Pin No.	Symbol	Function	Level	Note
1	SDA	Serial data input / output	I	
2	VCC	Power supply	P	
3	RS	Data / Command selection pin	I	
4	IOVCC	Power supply	P	
5	GND	Ground	P	
6	FMARK	Tearing effect input	I	
7	CLK	Serial clock	I	
8	RESET	Chip reset signa	I	
9	CS	Chip select	I	
10	LED+	Backlight anode	P	
11	GND	Ground	P	
12	LED-	Backlight cathode	P	

I: input, O: output, P: Power

3. Operating Specification

3.1 ABSOLUTE MAXIMUM RATINGS

Item	Symbol	Values		Unit	Remark
		Min.	Max.		
Power Voltage	VCC/IOVCC	-0.3	4.6	V	
Operation Temperature	T _{OP}	-20	60	°C	
Storage Temperature	T _{ST}	-30	70	°C	
LED Reverse Voltage	V _R	-	1.2	V	Each LED Note 2
LED Forward Current	I _F		25	mA	Each LED

Note 1: The absolute maximum rating values of this product are not allowed to be exceeded at any times. Should a module be used with any of the absolute maximum ratings exceeded, the characteristics of the module may not be recovered, or in an extreme case, the module may be permanently destroyed.

Note 2: V_R Conditions: Zener Diode 20mA

3.2 Typical Operation Conditions

Item	Symbol	Values			Unit	Remark
		Min.	Typ.	Max.		
Operating voltage	VCC	2.4	2.75	3.3	V	
	IOVCC	1.65	1.8	3.3	V	
Input Logic High Voltage	V _{IH}	0.7IOVCC	--	IOVCC	V	
Input Logic Low Voltage	V _{IL}	VSS	--	0.2IOVCC	V	

3.3 Backlight driving conditions

Item	Symbol	Values			Unit	Remark
		Min.	Typ.	Max.		
Voltage for LED Backlight	V_L	8.4	9.0	10.5	V	Note 1
Current for LED Backlight	I_L	--	20	--	mA	
LED life time	--	--	50000	--	Hr	Note 2

Note 1: The LED Supply Voltage is defined by the number of LED at $T_a=25^{\circ}\text{C}$ and $I_L=20\text{mA}$.

Note 2: The "LED life time" is defined as the module brightness decrease to 50% original brightness at $T_a=25^{\circ}\text{C}$ and $I_L=20\text{mA}$.

3.4 Timing Characteristics

Please refer to ST7789V2 IC specification for detailed information.

4.0 OPTICAL SPECIFICATIONS

Item	Symbol	Condition	Values			Unit	Remark	
			Min.	Typ.	Max.			
Viewing Angle (CR ≥ 10)	θ_L	$\Phi=180^\circ$ (9 O'CLOCK)	70	80	--	degree	Note 1	
	θ_R	$\Phi=0^\circ$ (3 O'CLOCK)	70	80	--			
	θ_T	$\Phi=90^\circ$ (12 O'CLOCK)	70	80	--			
	θ_B	$\Phi=270^\circ$ (6 O'CLOCK)	70	80	--			
Response Time	$T_{ON} + T_{OFF}$	Normal $\Theta = \Phi = 0^\circ$	--	30	35	msec	Note 3	
Contrast Ratio	CR		700	900	--	--	Note 4	
Color Chromaticity	Red		R_X	--	0.631	--	--	Note 2
			R_Y	--	0.330	--	--	Note 5
	Green		G_X	--	0.282	--	--	Note 6
			G_Y	--	0.544	--	--	
	Blue		B_X	--	0.138	--	--	
			B_Y	--	0.155	--	--	
	White		W_X	--	0.29	--	--	
			W_Y	--	0.31	--	--	
Luminance	L	400	500	--	cd/m ²	Note 6		
NTSC		--	50%	--	--			
Luminance Uniformity	YU	80	--	--	%	Note 7		

Test Conditions:

1. IL=20mA (Backlight current), the ambient temperature is 25°C.
2. The test systems refer to Note 2.

Note 1: Definition of viewing angle range

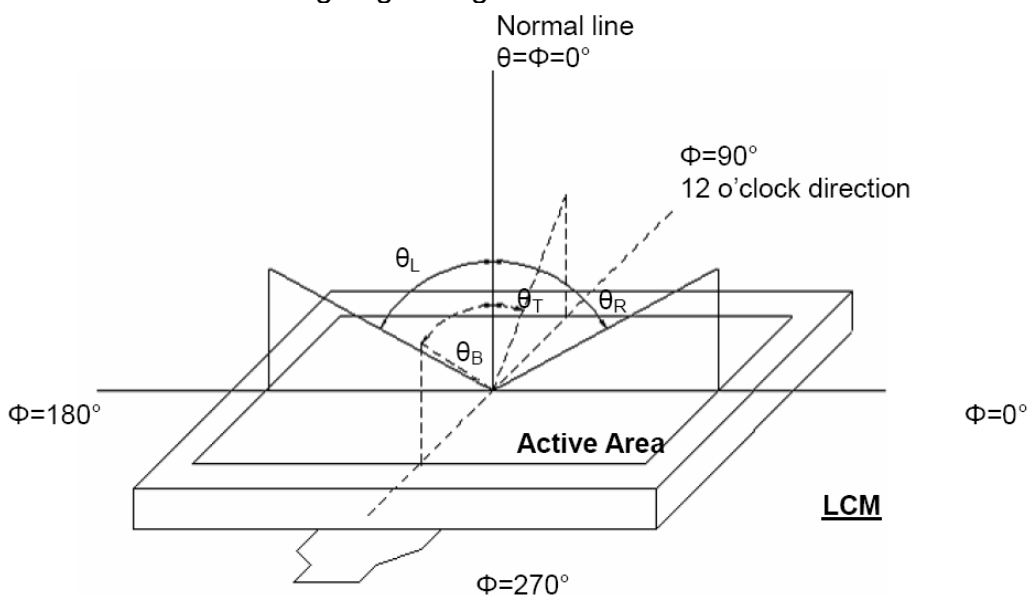

Figure 4.1 Definition of viewing angle.

Note 2: Definition of optical measurement system.

The optical characteristics should be measured in dark room. After 30 minutes operation, the optical properties are measured at the center point of the LCD screen. (Response time is measured by Photo detector TOPCON)



Figure 4.2 Optical measurement system setup

Note 3: Definition of Response time

The response time is defined as the LCD optical switching time interval between "White" state and "Black" state. Rise time (T_{ON}) is the time between photo detector output intensity changed from 90% to 10%. And fall time (T_{OFF}) is the time between photo detector output intensity changed from 10% to 90%.



Figure 4.3 Definition of response.

Note 4: Definition of contrast ratio

$$\text{Contrast ratio(CR)} = \frac{\text{Luminance measured when LCD on the "white" state}}{\text{Luminance measured when LCD on the "black" state}}$$

Note 5: Definition of color chromaticity (CIE1931)

Color coordinates measured at center point of LCD.

Note 6: All input terminals LCD panel must be ground while measuring the center area of the panel. The LED driving condition is $I_L=80\text{mA}$.

Note 7: Definition of Luminance Uniformity

Active area is divided into 9 measuring areas (Refer to Fig. 4.4).Every measuring point is placed at the center of each measuring area.

$$\text{Luminance Uniformity (Yu)} = \frac{B_{min}}{B_{max}}$$

L-----Active area length W----- Active area width

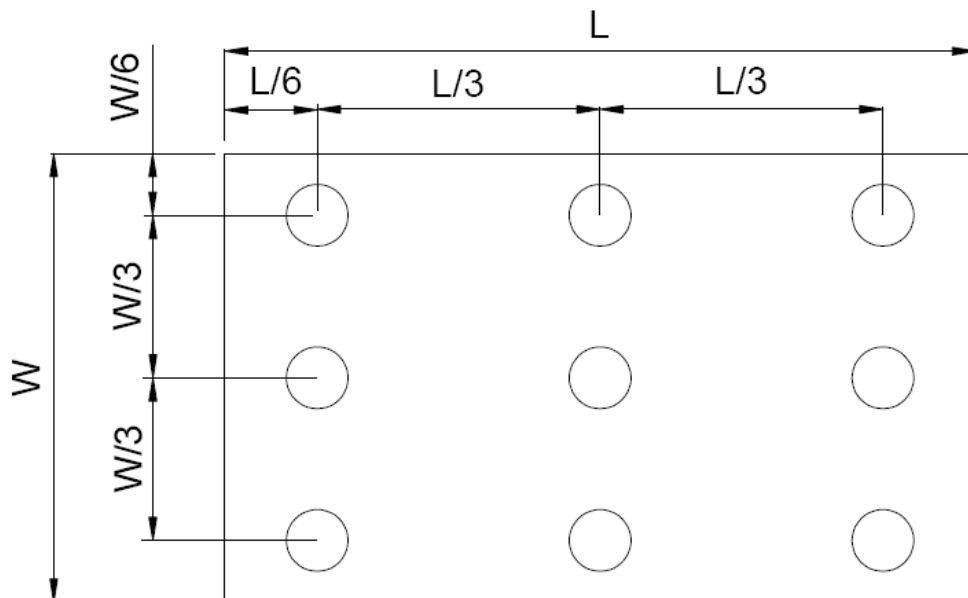

Figure 4.4 Definition of measuring points.

Bmax: The measured maximum luminance of all measurement position.

Bmin: The measured minimum luminance of all measurement position.

5. RELIABILITY TEST

ITEM	Condition	Sample size	Criterion
High Temp. Storage	70°C, 48 hrs	5pcs	Inspection after 2~4hours storage at room temperature, the sample shall be free from defects: 1.Air bubble in the LCD; 2.Sealleak; 3.Non-display; 4.Missing segments; 5. The surface shall be free from damage. 6. Contrast must be no more than 10% by the linearity tester. 7. Power must be no more than 10% by the linearity tester.
Low Temp. Storage	-30°C, 48 hrs	5pcs	
High Temp. Operation	60°C,48 hrs	5pcs	
Low Temp. Operation	-20°C, 48 hrs	5pcs	
Humidity operation	40°C,90%RH, 48 hrs	5pcs	
Humidity storage	60°C,90%RH, 48 hrs	5pcs	
Thermal shock	-30°C/30min → 70°C/30mins Total:16cycles	5pcs	
Simulated transport	Reciprocating, 190+/-10 Ring, 2 hours, amplitude 25.4MM	1Carton-box	After testing, there are no any defective appearances or electrical properties.
Packaging drop	Six faces, Three edge (Diagonal landing), The weight and height correspond to the following 0 to 45.4KG : 80CM ; 45.4-90.8KG : 60CM ; 90.8-454KG : 45CM ; OVER454KG: 40CM	1Carton-box	
ESD	1.Contact discharge method±4KV, 150pF/330Ω 10times (Can not face the role of IC)	5pcs	1. After testing, there are no any defective appearances or electrical properties. 2. It can be acceptable when all defective ESD disappears in the RESET.
	2.Air discharge method±8KV,150pF/330Ω 10times (Can not face the role of IC)	5pcs	

6. PRECAUTION FOR USING LCM

1. When design the product with this LCD Module, make sure the viewing angle matches to its purpose of usage.
2. As LCD panel is made of glass substrate, dropping the LCD module or banging it against hard objects may cause cracking or fragmentation. Especially at corners and edges.
3. Although the polarizer of this LCD Module has the anti-glare coating, always be careful not to scratch its surface. Use of a plastic cover is recommended to protect the surface of polarizer.
4. If the LCD module is stored below specified temperature, the LC material may freeze and be deteriorated. If it is stored above specified temperature, the molecular orientation of the LC material may change to Liquid state and it may not revert to its original state. And also excessive temperature and humidity could cause polarizer peel off or bubble. Therefore, the LCD module should always be stored within specified temperature and humidity range. If the LCD modules will be stored for a long time, the recommend temperature/humidity for the storage environment is:
Temperature : 15°C ~ 35°C / Relatively humidity: ≤80%
5. Meanwhile please follow other requirements below for storage:
 - Store with no touch on display surface by the anything else. If possible, store the LCD in the packaging situation when it was delivered.
 - If the original package is opened, please store in an anti-static polyethylene bag and seal it so as not to get fresh air outside enter into it.
 - LCD modules shall be stored in a dark place. And it shall not be exposed to sunlight nor fluorescent light in storage.

Note: If the storage time is over 1 year, the golden fingers of FPC might be slightly oxidized, but it won't affect the electrical performance, customer can use rubber to clean the golden fingers before assembly or directly assemble the display.

6. Saliva or water droplets must be wiped off immediately as those may leave stains or cause color changes if is remained there for a long time. And water vapor will cause corrosion of ITO electrodes. If the surface of LCD panel needs to be cleaned, wipe it swiftly with cotton or other soft dry cloth. If it is not still clean enough, blow a breath on the surface and wipe again. If needed, please just moisten cloth with one of the following solvents:
 - Isopropyl alcohol
 - Ethyl alcoholSolvents other than those mentioned above may damage the polarizer. Especially, do not use the following:
 - Water
 - Ketone
 - Aromatic solvents

7. The module should be driven according to the specified ratings to avoid malfunction and permanent damage. Applying DC voltage cause a rapid deterioration of LC material. Make sure to apply alternating waveform by continuous application of the M signal. Especially the power ON/OFF sequence should be kept to avoid latch-up of driver LSIs and DC charge up to LCD panel.
8. Mechanical Considerations
 - a) LCM are assembled and adjusted with a high degree of precision. Avoid excessive shocks and do not make any alterations or modifications. The following should be noted.
 - b) Do not tamper in any way with the tabs on the metal frame.
 - c) Do not modify the PCB by drilling extra holes, changing its outline, moving its components or modifying its pattern.
9. Static Electricity
 - a) Operator

Wear the electrostatics shielded clothes because human body may be statically charged if not ware shielded clothes. Never touch any of the conductive parts such as the LSI pads; the copper leads on the PCB and the interface terminals with any parts of the human body.

- b) Equipment

There is a possibility that the static electricity is charged to the equipment, which has a function of peeling or friction action (ex: conveyer, soldering iron, working table). Earth the equipment through proper resistance (electrostatic earth: 1×10^8 ohm).

Only properly grounded soldering irons should be used.

If an electric screwdriver is used, it should be well grounded and shielded from commutator sparks.

The normal static prevention measures should be observed for work clothes and working benches; for the latter conductive (rubber) mat is recommended.

ATM0154B1 (ZETTLER DISPLAYS) TFT MODULE VER1.9

c) Floor

Floor is the important part to drain static electricity, which is generated by operators or equipment. There is a possibility that charged static electricity is not properly drained in case of insulating floor. Set the electrostatic earth (electrostatic earth: 1×10^8 ohm).

d) Humidity

Proper humidity helps in reducing the chance of generating electrostatic charges. Humidity should be kept between 50%RH and 80%RH.

e) Transportation/storage

The storage materials also need to be anti-static treated because there is a possibility that the human body or storage materials such as containers may be statically charged by friction or peeling.

The modules should be kept in antistatic bags or other containers resistant to static for storage.

f) Soldering

Soldering anything to this TFT display would void the warranty.

g) Others

The laminator (protective film) is attached on the surface of LCD panel to prevent it from scratches or stains. It should be peeled off slowly using static eliminator.

Static eliminator should also be installed to the workbench to prevent LCD module from static charge.

10. Operation

- a) Driving voltage should be kept within specified range; excess voltage shortens display life.
 - b) Response time increases with decrease in temperature.
 - c) Display may turn black or dark blue at temperatures above its operational range; this is (however not pressing on the viewing area) may cause the segments to appear "fractured".
 - d) Mechanical disturbance during operation (such as pressing on the viewing area) may cause the segments to appear "fractured".
11. If any fluid leaks out of a damaged glass cell, wash off any human part that comes into contact with soap and water. The toxicity is extremely low but caution should be exercised at all the time.
 12. Disassembling the LCD module can cause permanent damage and it should be strictly avoided.
 13. LCD retains the display pattern when it is applied for long time (Image retention). To prevent image retention, do not apply the fixed pattern for a long time. Image retention is not a deterioration of LCD. It will be removed after display pattern is changed.
 14. Do not use any materials, which emit gas from epoxy resin (hardener for amine) and silicone adhesive agent (dealcohol or deoxym) to prevent discoloration of polarizer due to gas.
 15. Avoid the exposure of the module to the direct sunlight or strong ultraviolet light for a long time.

8. PACKAGE DRAWING
T.B.D.

9. INSPECTION SPECIFICATION

1. Inspection conditions

Inspection performed under the following conditions is recommended.

Temperature: 25±5°C

Humidity: 65%±10%RH

Viewing Angle: Normal viewing Angle (90°±45°);

Illumination: Single fluorescent lamp (800~1200 LUX);

Viewing distance: 25-35cm, time: 5-10s;

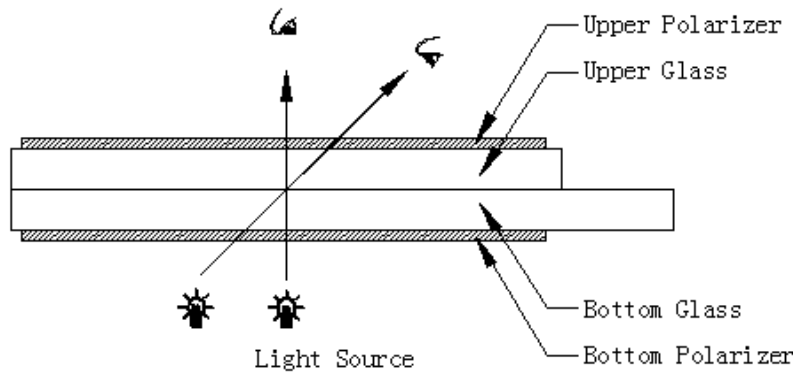

2. Definition

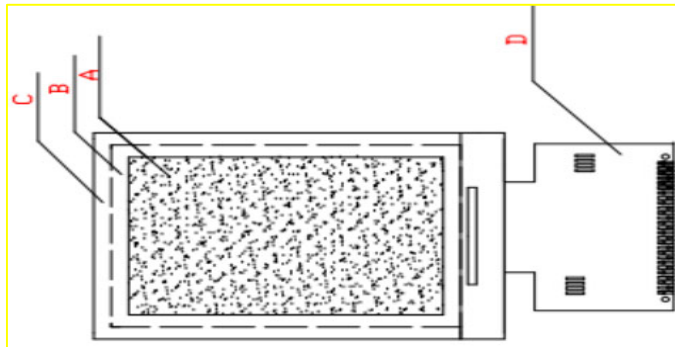

Zone A: LCD AA

Zone B: Viewing Area

Zone C: Outside of the Viewing Area

Note:

As a general rule, visual defects in Zone C can be ignored when it doesn't effect product function or appearance after assembly by customer.

3.Sampling Plan

According to GB/T 2828-2003; , normal inspection, Class II

AQL:

Major defect	Minor defect
0.65	1.5

LCD: Liquid Crystal Display, TP: Touch Panel, LCM: Liquid Crystal Module

ATM0154B1 (ZETTLER DISPLAYS) TFT MODULE VER1.9

No	Items to be inspected	Criteria	Classification of defects
1	Functional defects	1) No display 2) Display abnormally 3) Missing vertical, horizontal segment 4) Short circuit 5) Back-light no lighting, flickering and abnormal lighting 6)Cross-Talk 7)Noise 8)Color contrast	Major
2	Missing	Missing component	Major
3	Outline dimension	Overall outline dimension beyond the drawing is not allowed	
4	Color tone	Color unevenness, refer to limited sample	
5	Soldering appearance	Good soldering, Peeling off is not allowed.	Minor
6	LCD/Polarizer	Black/White spot/line, scratch, crack, etc.	Major
7	mura	ND5%, 128 gray	
8	Cross-talk	≤ 5%	Minor

4. Criteria (Visual)

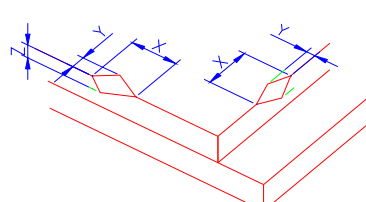
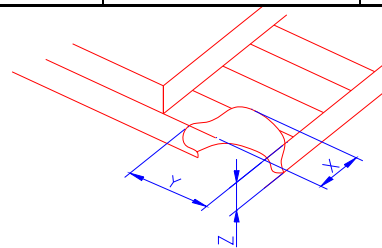
Number	Items	Criteria(mm)						
1.0 LCD Crack/Broken	(1) The edge of LCD broken	 <table border="1" style="margin-left: auto; margin-right: auto;"> <thead> <tr> <th>X</th> <th>Y</th> <th>Z</th> </tr> </thead> <tbody> <tr> <td>≤1.5mm</td> <td><Inner border line of the seal</td> <td>≤T/2</td> </tr> </tbody> </table>	X	Y	Z	≤1.5mm	<Inner border line of the seal	≤T/2
X	Y	Z						
≤1.5mm	<Inner border line of the seal	≤T/2						
NOTE: X: Length Y: Width Z: Height L: Length of ITO, T: Height of LCD	(2)LCD corner broken	 <table border="1" style="margin-left: auto; margin-right: auto;"> <thead> <tr> <th>X</th> <th>Y</th> <th>Z</th> </tr> </thead> <tbody> <tr> <td>≤3mm</td> <td>≤2mm</td> <td>≤T</td> </tr> </tbody> </table>	X	Y	Z	≤3mm	≤2mm	≤T
X	Y	Z						
≤3mm	≤2mm	≤T						

ATM0154B1 (ZETTLER DISPLAYS) TFT MODULE VER1.9

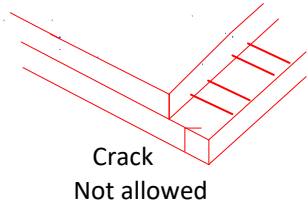
	(3) LCD crack	 <p style="text-align: center;">Crack Not allowed</p>
--	---------------	---

Number	Items	Criteria (mm)																																								
2.0	Spot defect	<p>① light dot (LCD/TP/Polarizer black/white spot, light dot, pinhole, dent, stain)</p> <table border="1" style="width: 100%; border-collapse: collapse;"> <thead> <tr> <th rowspan="2" style="width: 30%;">Zone Size (mm)</th> <th colspan="3">Acceptable Qty</th> </tr> <tr> <th style="width: 15%;">A</th> <th style="width: 15%;">B</th> <th style="width: 15%;">C</th> </tr> </thead> <tbody> <tr> <td>$\Phi \leq 0.10$</td> <td colspan="2" style="text-align: center;">Ignore</td> <td rowspan="4" style="text-align: center; vertical-align: middle;">Ignore</td> </tr> <tr> <td>$0.10 < \Phi \leq 0.15$</td> <td colspan="2" style="text-align: center;">2</td> </tr> <tr> <td>$0.15 < \Phi \leq 0.2$</td> <td colspan="2" style="text-align: center;">1</td> </tr> <tr> <td>$0.2 < \Phi$</td> <td colspan="2" style="text-align: center;">0</td> </tr> </tbody> </table> <p>② Dim spot (LCD/TP/Polarizer dim dot, light leakage, dark spot)</p> <table border="1" style="width: 100%; border-collapse: collapse;"> <thead> <tr> <th rowspan="2" style="width: 30%;">Zone Size (mm)</th> <th colspan="3">Acceptable Qty</th> </tr> <tr> <th style="width: 15%;">A</th> <th style="width: 15%;">B</th> <th style="width: 15%;">C</th> </tr> </thead> <tbody> <tr> <td>$\Phi \leq 0.1$</td> <td colspan="2" style="text-align: center;">Ignore</td> <td rowspan="4" style="text-align: center; vertical-align: middle;">Ignore</td> </tr> <tr> <td>$0.1 < \Phi \leq 0.2$</td> <td colspan="2" style="text-align: center;">$2(D > 10\text{mm})$</td> </tr> <tr> <td>$0.2 < \Phi \leq 0.3$</td> <td colspan="2" style="text-align: center;">1</td> </tr> <tr> <td>$\Phi > 0.3$</td> <td colspan="2" style="text-align: center;">0</td> </tr> </tbody> </table>	Zone Size (mm)	Acceptable Qty			A	B	C	$\Phi \leq 0.10$	Ignore		Ignore	$0.10 < \Phi \leq 0.15$	2		$0.15 < \Phi \leq 0.2$	1		$0.2 < \Phi$	0		Zone Size (mm)	Acceptable Qty			A	B	C	$\Phi \leq 0.1$	Ignore		Ignore	$0.1 < \Phi \leq 0.2$	$2(D > 10\text{mm})$		$0.2 < \Phi \leq 0.3$	1		$\Phi > 0.3$	0	
	Zone Size (mm)	Acceptable Qty																																								
A		B	C																																							
$\Phi \leq 0.10$	Ignore		Ignore																																							
$0.10 < \Phi \leq 0.15$	2																																									
$0.15 < \Phi \leq 0.2$	1																																									
$0.2 < \Phi$	0																																									
Zone Size (mm)	Acceptable Qty																																									
	A	B	C																																							
$\Phi \leq 0.1$	Ignore		Ignore																																							
$0.1 < \Phi \leq 0.2$	$2(D > 10\text{mm})$																																									
$0.2 < \Phi \leq 0.3$	1																																									
$\Phi > 0.3$	0																																									
	Line defect (LCD /Polarizer black/white line, scratch, stain)	<table border="1" style="width: 100%; border-collapse: collapse;"> <thead> <tr> <th style="width: 30%;">Width(mm)</th> <th style="width: 30%;">Length(mm)</th> <th style="width: 40%;">Acceptable Qty</th> </tr> </thead> <tbody> <tr> <td>$\Phi \leq 0.03$</td> <td style="text-align: center;">Ignore</td> <td style="text-align: center;">Ignore</td> </tr> <tr> <td>$0.03 < W \leq 0.05$</td> <td style="text-align: center;">$L \leq 1.5$</td> <td style="text-align: center;">1</td> </tr> <tr> <td>$0.05 < W$</td> <td colspan="2" style="text-align: center;">$W > 0.05$ for Spot defect</td> </tr> </tbody> </table>	Width(mm)	Length(mm)	Acceptable Qty	$\Phi \leq 0.03$	Ignore	Ignore	$0.03 < W \leq 0.05$	$L \leq 1.5$	1	$0.05 < W$	$W > 0.05$ for Spot defect																													
Width(mm)	Length(mm)	Acceptable Qty																																								
$\Phi \leq 0.03$	Ignore	Ignore																																								
$0.03 < W \leq 0.05$	$L \leq 1.5$	1																																								
$0.05 < W$	$W > 0.05$ for Spot defect																																									

ATM0154B1 (ZETTLER DISPLAYS) TFT MODULE VER1.9

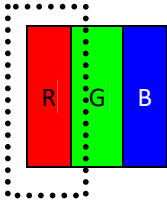
3.0	Polarizer scratch	<table border="1"> <thead> <tr> <th>Width(mm)</th> <th>Length(mm)</th> <th>Acceptable Qty</th> </tr> </thead> <tbody> <tr> <td>$W \leq 0.03$</td> <td>Ignore</td> <td>Ignore</td> </tr> <tr> <td>$0.03 < W \leq 0.05$</td> <td>$L \leq 5$</td> <td>1</td> </tr> <tr> <td>$0.05 < W$</td> <td>0</td> <td>0</td> </tr> </tbody> </table>	Width(mm)	Length(mm)	Acceptable Qty	$W \leq 0.03$	Ignore	Ignore	$0.03 < W \leq 0.05$	$L \leq 5$	1	$0.05 < W$	0	0		
	Width(mm)	Length(mm)	Acceptable Qty													
$W \leq 0.03$	Ignore	Ignore														
$0.03 < W \leq 0.05$	$L \leq 5$	1														
$0.05 < W$	0	0														
	Polarizer Bubble	<table border="1"> <thead> <tr> <th>Zone Size (mm)</th> <th>Acceptable Qty</th> </tr> </thead> <tbody> <tr> <td>$\Phi \leq 0.1$</td> <td>Ignore</td> </tr> <tr> <td>$0.1 < \Phi \leq 0.2$</td> <td>2 ($D \geq 15\text{mm}$)</td> </tr> <tr> <td>$0.2 < \Phi$</td> <td>0</td> </tr> </tbody> </table>	Zone Size (mm)	Acceptable Qty	$\Phi \leq 0.1$	Ignore	$0.1 < \Phi \leq 0.2$	2 ($D \geq 15\text{mm}$)	$0.2 < \Phi$	0						
Zone Size (mm)	Acceptable Qty															
$\Phi \leq 0.1$	Ignore															
$0.1 < \Phi \leq 0.2$	2 ($D \geq 15\text{mm}$)															
$0.2 < \Phi$	0															
4.0	SMT	According to the <Acceptability of electronic assemblies> IPC-A-610C class 2 standard. Component missing or function defect are Major defect, the others are Minor defect.														
5.0	TFT	<table border="1"> <thead> <tr> <th>distinguish</th> <th>type</th> <th>Acceptable Qty</th> </tr> </thead> <tbody> <tr> <td rowspan="2">Bright dot</td> <td>Any color window</td> <td>0</td> </tr> <tr> <td>Adjacent Bright dot</td> <td>0</td> </tr> <tr> <td rowspan="2">Dark dot</td> <td>Dark dot</td> <td>2</td> </tr> <tr> <td>Adjacent Dark dot</td> <td>0</td> </tr> </tbody> </table> <p>Note: the red (R), green, blue (G), (B) 3 points constitute a pixel</p>	distinguish	type	Acceptable Qty	Bright dot	Any color window	0	Adjacent Bright dot	0	Dark dot	Dark dot	2	Adjacent Dark dot	0	 <p>Dot</p>
distinguish	type	Acceptable Qty														
Bright dot	Any color window	0														
	Adjacent Bright dot	0														
Dark dot	Dark dot	2														
	Adjacent Dark dot	0														